

### DIMENSIONS (mm)

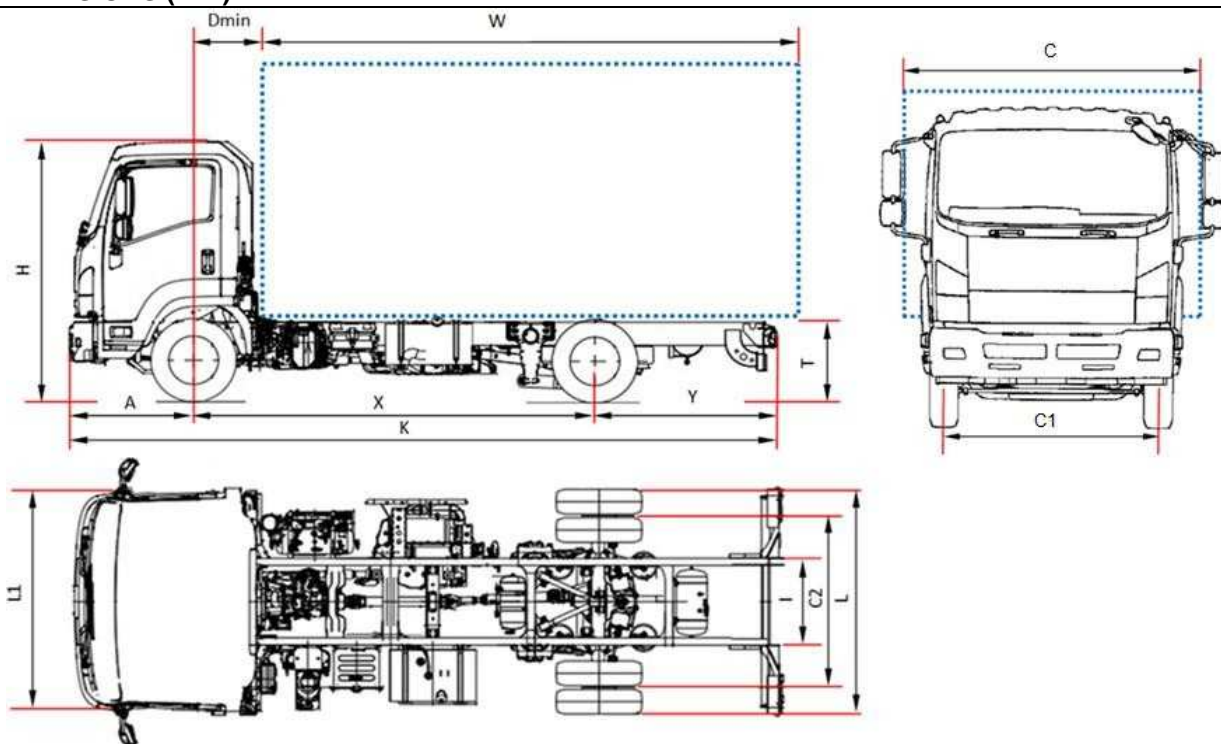

MODEL NAME		F 12 J	F 12 L	F 12 N	F 12 Q
Wheelbase	X	3790	4360	4990	5320
Overall length	K	6620	7490	8390	8690
Body length min <sup>1</sup>	W	4735	5605	6505	6805
Body length max <sup>1</sup>	W	5085	5955	6855	7155
Rear overhang	Y	1665	1955	2225	2195
Chassis height (unladen)	T	785			
Overall height (unladen)	H	2585			
Rear axle width	L	2205			
Cab width <sup>2</sup>	L1	2195			
Body width <sup>3</sup>	C	2406 / 2500			
Front axle to back of cab	Dmin	710			
Front overhang	A	1175			
Frame internal size	I	840			
Front track	C1	1805			
Rear track	C2	1670			
Minimum Road Clearance	-				
<b>WEIGHT (kg)</b>					
Unladen weight <sup>4</sup>		4155	4215	4285	4295
Unladen weight front axle		2650	2690	2715	2725
Unladen weight rear axle		1505	1525	1570	1570
Minimum weight vehicle equipped					
Gross vehicle weight		11990			
Front/rear total weight		4480 / 8480			
Max trailer weight unbraked/braked		3500			
<sup>1.</sup> The length of the body refers to a uniformly loaded vehicle, up to the maximum capacity on each axle (dimensions declared in C.O.C. with no chassis modifications). <sup>2.</sup> Excluding turn signal and side mirrors <sup>3.</sup> Possible widths with optional mirror brackets short 2195/2286 – medium 2286/2406 – extra large 2500/2550 <sup>4.</sup> The Unladen weight include spare wheel, full fuel tank and driver 75 kg. AMT: +25 kg					

### ALL DATA MUST BE CONFIRMED BY THE TYPE APPROVAL CERTIFICATE

Note: Dimensions and weight are given as guide only. Bodybuilders are responsible for ensuring all legal requirements are met. Isuzu shall have no liability whatsoever should information supplied have incorrect data, description or illustrations.

W/B (mm) J 3790 - L 4360 - N 4990 - Q 5320

2017

<b>Equipment</b>	Automated transmission NEES 2 with HSA		
<b>Standard features</b>	<ul style="list-style-type: none"> <li>• EGR – DPD (Diesel particulate diffuser)</li> <li>• SCR con Ad-Blue®</li> <li>• Multi information display</li> <li>• Air conditioning</li> <li>• Speed limiter (90km/h)</li> <li>• Engine exhaust brake</li> <li>• Steering wheel adjustable</li> <li>• Air suspension seat</li> <li>• Electric windows</li> <li>• Side mirrors heated and electric</li> <li>• Warning reverse</li> <li>• Radio with USB</li> <li>• Head lamps control leveling</li> <li>• Immobilizer</li> <li>• Central locking with remote control</li> <li>• Cruise control</li> <li>• Daytime running line</li> <li>• Fog lamps</li> </ul>		
<b>Engine</b>	<p>ISUZU 4HK1E6C Diesel, 4 cylinders 16-valve, common rail direct-injection intercooler with Variable-geometry turbocharger.            Displacement 5193 cm<sup>3</sup>            Power max 177kW (240HP) at 2400 giri/min            Torque max 765 Nm a 1600 giri/min            Emission level EURO VI update OBD-C</p>		
<b>Tank capacity</b>	Fuel	Lt 140	Ad-Blue® Lt 16
<b>Safety system</b>	<p>ABS            ESC (Electronic Stability Control) with ASR            LDWS (Lane Departure Warning System)  <b>AEBS (Active Emergency Braking System)</b>            SRS air-bags driver</p>		
<b>Transmission ratios</b>	<p>6 gear MZW6P – 6.615 - 4.095 - 2.358 - 1.531 - 1.000 - 0.722;            Reverse 6.615; Final gear ratio W/B J 5.125 (41/8) - Final gear ratio other W/B 4.555 (41/9)</p>		
<b>Transmission control</b>	MANUAL	NEES 2 – Automated T/M	
<b>Frame dimension</b>	Width 60 mm, height 225 mm, thickness 6 mm		
<b>Seat number</b>	3		
<b>Tire</b>	245/75 R19,5, with rear twin wheels		
<b>Brake</b>	Front and rear: drum brake. Wheel parking brake: rear, air control. Brake type: full air		
<b>Suspension</b>	Front: Multi taper leaf spring. Rear: 4-bag Air Suspension with height control. Front and rear stabilizer shaft		
<b>Electrical system</b>	2 battery 115 A - System 24V - Alternator 90A		

**ALL DATA MUST BE CONFIRMED BY THE TYPE APPROVAL CERTIFICATE**

Note: Dimensions and weight are given as guide only. Bodybuilders are responsible for ensuring all legal requirements are met. Isuzu shall have no liability whatsoever should information supplied have incorrect data, description or illustrations.